

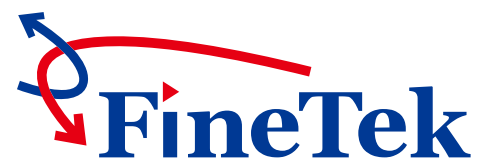

Monitoring Devices For Conveyor System



www.fine-tek.com



SAFETY CABLE PULL SWITCH FOR EMERGENCY OR NORMAL SHUT-OFF

SRS

Belt conveyor safety cable pull switches are designed for providing a switching system to isolate the power to conveyor system and other equivalent process equipment in the emergency condition.

The cable pull switches are actuated by a plastic coated steel wire, which are placed along-side the conveyor. When you pull on the cable at any point, it will trip and automatically lock the switches, deenergizing the conveyor starter contactor. Each switch is bi-directional in operation and has two cable fitted to it from opposite directions terminated with a spring at the anchor points, please see drawing 4 the springs will operate the switch on cable breakage.

After tripping the mechanical latch can be released only on the switch itself by the reset lever.

APPLICATIONS

emergency or normal stop for below facilities

- Conventional Belt Conveyors
- Shuttle Conveyors
- Bucket Elevators
- Packaging Lines
- Stockpile/Reclaim systems, Cranes, Shovels, Draglines
- Ship Loading / Unloading System
- Horizontal Feed Systems

DIMENSION

SRS

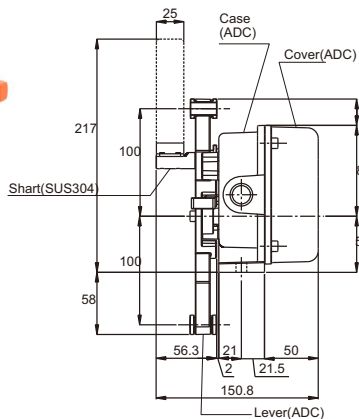

Operation-indicating plate
Color: MUNSSELL 5R4/13
(SS400)

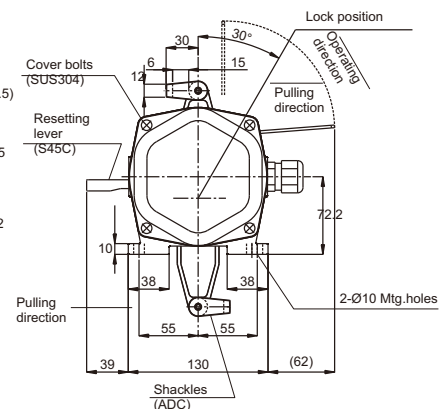
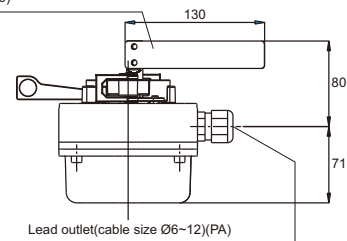

FEATURES

- Universal design for bi-direction activation
- Compact design for tight-fit areas, IP67 rugged die cast aluminum housing
- Manual reset lever
- Easily orientated at either end or intermediate position in pull cable run
- Cable Pull 30° for shutting down system
- Highly visible black arm easily shows condition of the switch, indicating alarm or normal
- SRS-170, Explosion-proof
- Ex tD A21 IP67 T85°C

SPECIFICATION

Switching Capacity	15A, 125/250 Vac 6A 30 Vdc SPDTx2
Action Force	49 ± 9.8n (5 ± 1kgf.m)
Reset Way	Manual
Ambient Temp.	-20~60°C
Enclosure Protection Grade	IP67
Enclosure Material	Die cast ADC
Weight	Approx. 2.9kg

ORDER INFORMATION

SRT-1 0

Type _____

0: Standard type

7: Explosion-proof type

SPEED MONITOR-ED4000

ED4000

ED4000(SM4) Speed Monitor is a totally new rotational speed monitoring equipment; it uses the principle of photo detector and microprocessor to accurately calculate a wide range of rotational speed. It detects rang 1~999rpm and the rotational speed display on 7-seg led.

There is a contact relay that could be used either for alarm or control purposes during the monitoring process. The alarm set point could be directly set by numerical knobs which is more convenient and more accurate than conventional means. It comes equipped with analog signal output which could be utilized for various display indications and more precise control. It is ideal for applications in monitoring low speed, stop and overload situations.

APPLICATION

- Low speed and overload protection monitoring of various conveyer systems
- Networked circuits to form sequential start or stop
- Frequently used machines: Grain and coal storage bucket elevators and belt conveyer machines

SPECIFICATION

- Measuring Range : 0~999 rpm.
- 7-seg led display 0~999
- Alarm Set point : 1~1999 rpm by rotary switch.
- Alarm Conditions : Underspeed, standstill, power failure.
- Startup Delay : 0 second or 15 Seconds. Selectable
- Alarm Contact Rating : SPDT 5A/250Vac.
- Alarm Delay : 0, 3, 6, 9,....,27 seconds. Selectable
- Speed Analog Output : 4~20mA
- (Signal Range Selectable : 100/200/500/1000rpm).
- Power Supply : 85~265Vac, 50/60Hz
- Power Consumption : 6VA.
- Operating Temperature : -20°C~70°C.
- Housing : Cast Aluminum.
- Protection : IP65
- Cable Entry : 1/2"NPT X 2 hole.

FEATURES

- Maximum monitoring range 1~999rpm.
- 7-seg led display 0~999
- Alarm monitoring: low speed, stop, reverse, blackout and overload.
- Start up delay function allow motor to run up gradually.
- Alarm delay function can avoid fault alarm which many caused by temporary slow down or load changed.
- Selectable rotate direction for both CCW and CW makes installation more versatile.
- Light pulses are not affected by environmental conditions.
- Complementary to FineTek PB/PM series digital Panel meter to indicate speed.

Special Function (built in function)

4~20mA output, proportional to selectable speed range like 100rpm, 200rpm, 500rpm and 1,000rpm.

DIMENSIONS

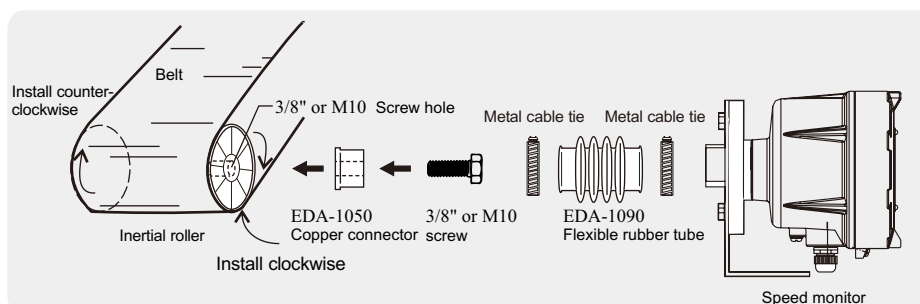
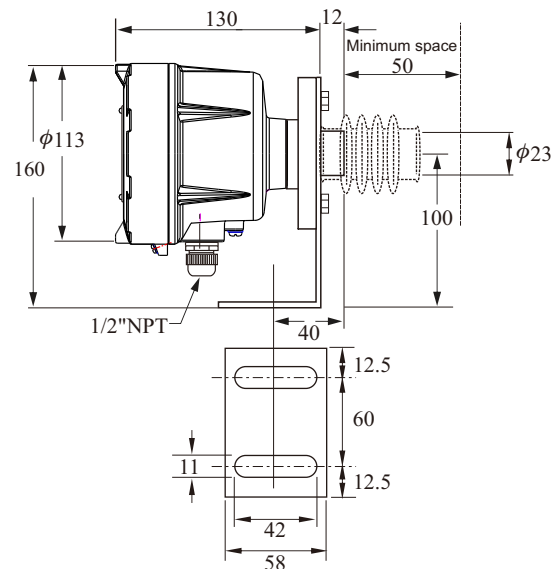

DESCRIPTION OF PANEL

- ① Set point rotary switch
- ② Power & Alarm indicator (Green/Red)
- ③ Start Up Delay Selection Switch
- ④ 4-20mA output range Selection Switch
- ⑤ 7 Segment display

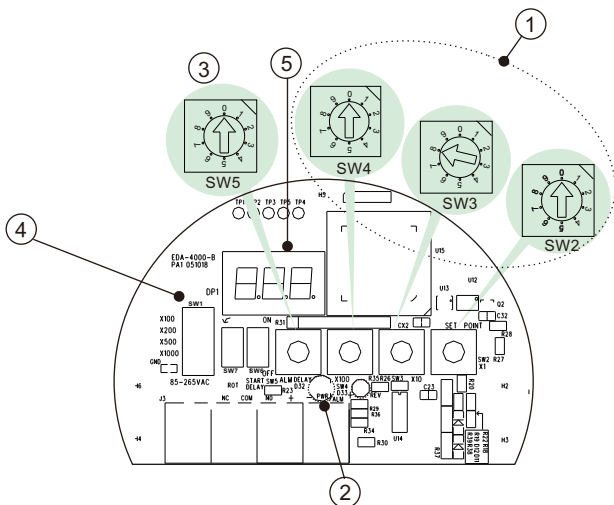

ED TYPICAL APPLICATION

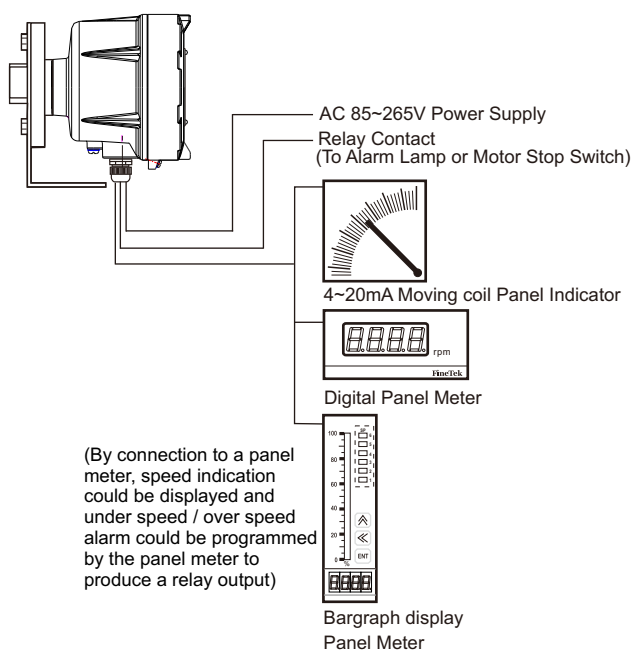

DESCRIPTION OF OPERATION

1. Set point rotary switch

The function of this switch is for setting alarm position. The rotary switch consists of 3 buttons, including x100, x10 and x1. If the setting is at 321rpm, then rotate the SW4 to position 3, rotate the SW3 to position 2 and rotate the SW2 to 1.

2. Alarm indicator (Red)/Power indicator (Green)

1. When the monitor detects the speed lower than the setting point and reach to the alarm delay time or the motor reversed, the alarm relay is actuated and the red light is on spontaneously; vice versa, the red light is off when the speed is rotated back to normal.
2. The function of the green light is to indicate power situation. After switching on the start up delay function and blinking for 15 seconds, the power indicator lights up.

3. Knob time-delay switch

This allows motor speed up slowly without immediate alarm. 0~9 stands for 3~30 seconds. Adjustment unit is at 3 seconds.

Knob point	0	1	2	3	4	5	6	7	8	9
Delay time	3 sec	6 sec	9 sec	12 sec	15 sec	18 sec	21 sec	24 sec	27 sec	30 sec

4. 4-20mA output range Selection Switch

This switch is to convert the detected speed into proportional current output. There are four selections which are 100rpm, 200rpm, 500rpm, 1000rpm. If setting at 500rpm, then the input speed of 0~500 rpm will be converted to 4~20mA output. For example, if the detected speed is at 250rpm, then the current output is 12mA.

CONTROL CIRCUIT DIAGRAM

Below is the diagram of control circuit. Motor speed is monitored by ED4000 (SM4). Motor starts to speed up after activation. ED4000(SM4) starts to monitor after delay time being activated. It monitors if motor is under low speed. When speed is too low, alarm will be issued to stop motor running.

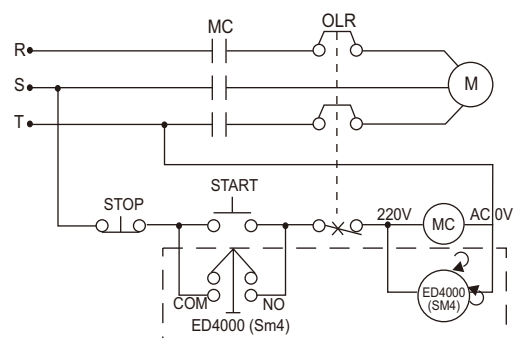

SPEED MONITOR- EDX10

WORKING PRINCIPLE

EDX10 is a brand new speed monitoring device exclusively designed for a belt conveyor, which monitors the rotation speed by using the optoelectronic switch or magnetic induction part. During this process, it provides an output contact SPDT for alarm or control. The alarm setting is determined by the scale on the adjustment knob, which is convenient and fast. Based on the conventional analog design, it uses a simple, stable and low-cost circuit, which makes it economical.

SPECIFICATION

Working power supply	110 VAC or 220 VAC $\pm 20\%$, 50/60 Hz , 24VDC $\pm 20\%$
Speed measurement range	0~150 rpm
Rotation direction	Can monitor clockwise and counter-clock wise directions simultaneously
Alarm condition	Overly-low rotation speed then stops
Startup delay time	0-second or 30-second switch
Output type	Relay output 1SPDT
Contact capacity	5A / 250VAC, 5A / 30VDC
Working temperature	-40°C~85°C
Housing material	Aluminum alloy, baked finish
Connection of inlet port	1/2"NPT housing protection level: IP-65
Reproducibility of alarm setting	$\pm 5\%$

DIMENSIONS

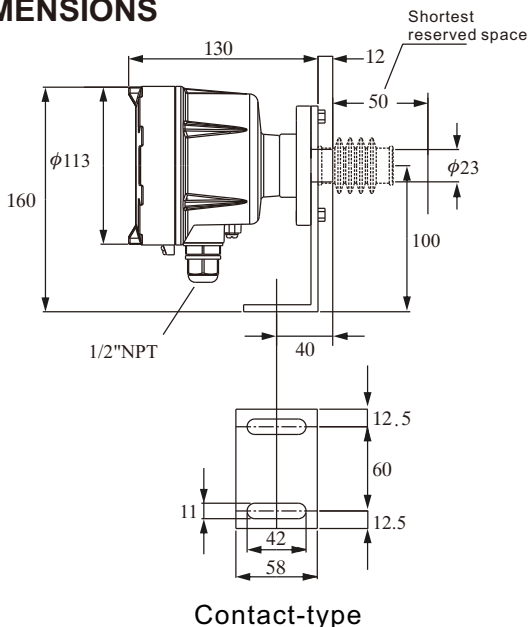

Contact-type

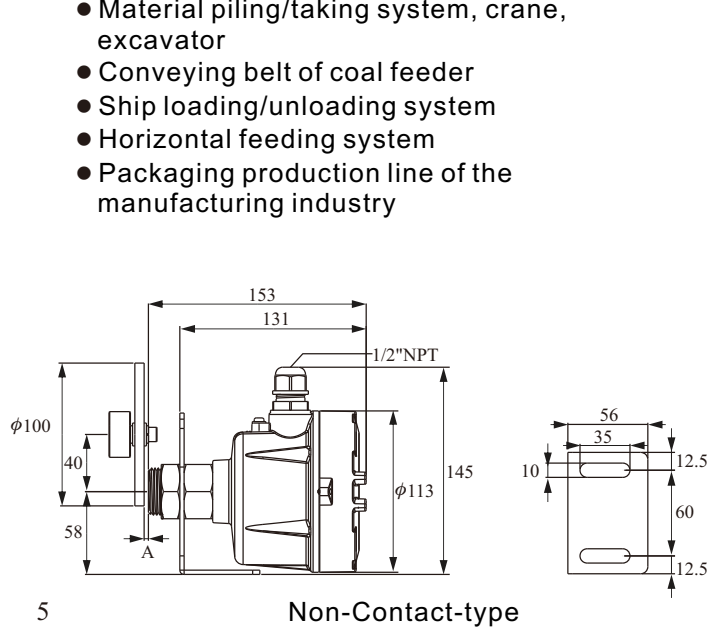

Non-Contact-type

FEATURES

- The alarm point setting of the speed monitor adopts a knob type operation, which is simple and fast.
- Based on the field application requirements, you may select the startup delay alarm function, so as to prevent false alarm when the device is accelerating at startup.
- Status indicator is clear, so user may determine whether the current rotation speed is normal.
- Universal relay output type is used, which doesn't require complicated wiring procedure.
- The output delay function can avoid false alarm when the rotation speed is fluctuating at the moment of material dropping.
- Contact and non-contact structural design are available, so user may select proper installation type based on the field requirements.

APPLICATION

It is widely applied in the industrial fields such as metallurgy, quarry, cement, steel, port, grain, power, pulp & paper, and resource recycling, which is used for monitoring protection of skid, overly-low speed and overload of various belt conveyors. When applied in the chain line, it can make up sequential startup or stop.

For instance:

- Conventional belt conveyor
- Chain cableway conveyor
- Reciprocating conveyor
- Bucket elevator
- Ring apron conveyor
- Plate feeding conveyor
- Material piling/taking system, crane, excavator
- Conveying belt of coal feeder
- Ship loading/unloading system
- Horizontal feeding system
- Packaging production line of the manufacturing industry

PANEL CONFIGURATION DIAGRAM

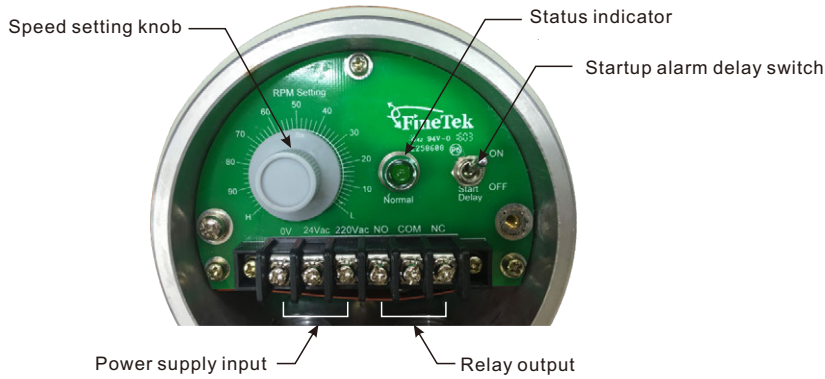

INSTALLATION INSTRUCTION

Contact type

Tap the 3/8" (or M10) screw hole in a central towards the axis direction of the driven wheel on the device to be monitored; fasten the copper connector on the rotation axis with the screw. And then set up a scaffold in front of the reversed rotation axis, align the axis center of the speed monitor and the driven wheel, and then fix it. Finally, connect with the rubber bellow and fasten the metal straps to finish the installation.

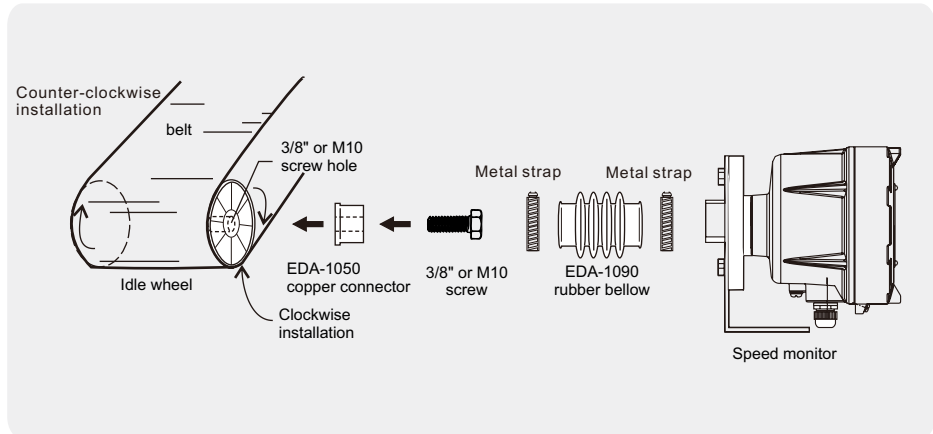

Non-contact type (Wheel axis tapping)

Tap the 3/8" (or M10) screw hole from the center towards the axis of the driven wheel on the device to be monitored, and then fix the sensing plate with screws. When fixing, it needs to go through the flat washer and spring washer. Fix the machine body on the corresponding position with the fixing plate. Finally, keep a 3~5mm distance between the probe in front of the body and the sensing plate to finish the installation.

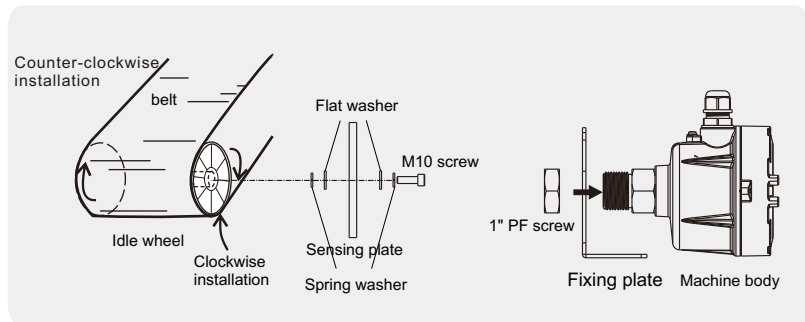

SPEED MONITOR- EDX10



EDX10

Sensing type

0: Contact type

1: Non-contact type

Working power supply

A: 110/220Vac, 50/60Hz

B: 24Vdc

Output type

R: Single relay output, 5A/250Vac